

TILE INSERT GRATES

TABLE OF CONTENTS

STI21 – 21mm depth – 1.0m Length	2
STI21 – 21mm depth – 1.6m Length	3
STI21 – 21mm depth – 2.0m Length	4
STI21 – 21mm depth – 3.0m Length	5
STI21 – 21mm depth – 5.6m Length	6
STI26 – 26mm depth – 1.0m Length	7
STI26 – 26mm depth – 1.6m Length	8
STI26 – 26mm depth – 2.0m Length	9
STI26 – 26mm depth – 3.0m Length	10
STI26 – 26mm depth – 5.6m Length	11
TIP35 – 35mm depth – 1.0m Length	12
TIP35 – 35mm depth – 1.6m Length	13
TIP35 – 35mm depth – 2.0m Length	14
TIP35 – 35mm depth – 3.0m Length	15
TIP35 – 35mm depth – 5.6m Length	16

PRODUCT SPECIFICATIONS

Product	Slimline Tile Insert 21 (STI21)
Code	STI21-S-1, STI21-M-1, STI21-G-1, STI21-BN-1
Colours Available	Silver, Midnight, Gold, Brushed Nickel
Length	1000mm
Width	100mm
Depth	21mm
Material	Anodised Aluminium
Weight	1.3kg
Applications	Indoor and Outdoor
Features	<ul style="list-style-type: none"> • Thinnest Tile Insert available • Suitable for tiles up to 10mm thick • Easy roll out feature for cleaning and maintenance • Lifetime Rustproof Warranty • UV Stable
Scope of Use	DN90 72mm and 80mm
Load Rating	Class B - Maximum Load at 10.2 tons

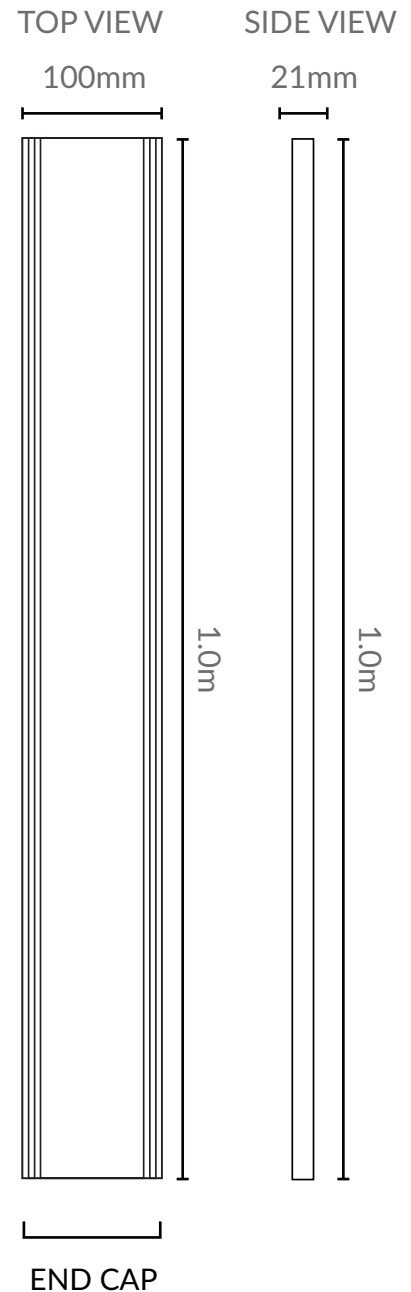

Minimum 72mm waste outlet recommended

* Regular, gentle cleaning with soapy water is recommended. Do not use abrasive cloths or acidic chemicals on the grates.

PRODUCT SPECIFICATIONS

Product	Slimline Tile Insert 21 (STI21)
Code	STI21-S-1.6, STI21-M-1.6, STI21-G-1.6, STI21-BN-1.6
Colours Available	Silver, Midnight, Gold, Brushed Nickel
Length	1600mm
Width	100mm
Depth	21mm
Material	Anodised Aluminium
Weight	2.2kg
Applications	Indoor and Outdoor
Features	<ul style="list-style-type: none"> • Thinnest Tile Insert available • Suitable for tiles up to 10mm thick • Easy roll out feature for cleaning and maintenance • Lifetime Rustproof Warranty • UV Stable
Scope of Use	DN90 72mm and 80mm
Load Rating	Class B - Maximum Load at 10.2 tons

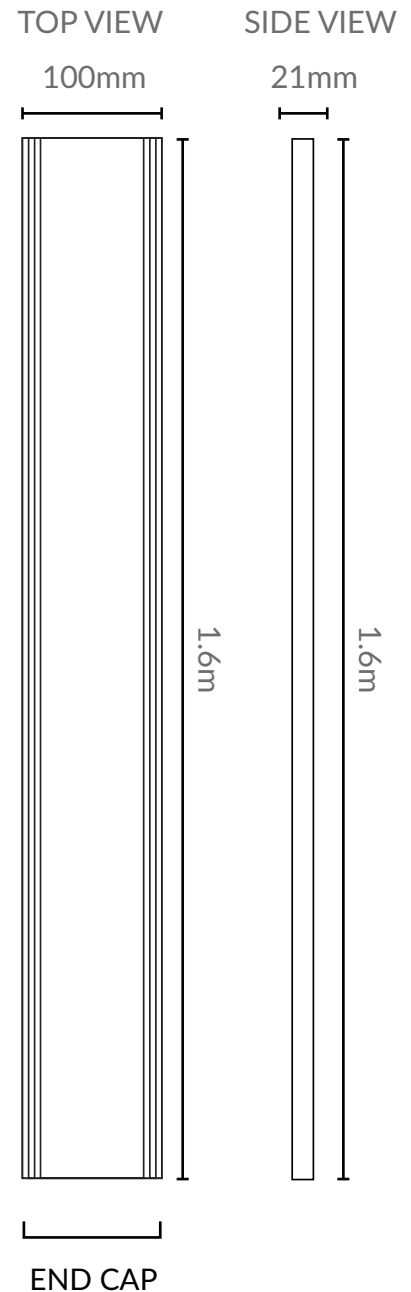

Minimum 72mm waste outlet recommended

* Regular, gentle cleaning with soapy water is recommended. Do not use abrasive cloths or acidic chemicals on the grates.

PRODUCT SPECIFICATIONS

Product	Slimline Tile Insert 21 (STI21)
Code	STI21-S-2, STI21-M-2, STI21-G-2, STI21-BN-2
Colours Available	Silver, Midnight, Gold, Brushed Nickel
Length	2000mm
Width	100mm
Depth	21mm
Material	Anodised Aluminium
Weight	2.7kg
Applications	Indoor and Outdoor
Features	<ul style="list-style-type: none"> • Thinnest Tile Insert available • Suitable for tiles up to 10mm thick • Easy roll out feature for cleaning and maintenance • Lifetime Rustproof Warranty • UV Stable
Scope of Use	DN90 72mm and 80mm
Load Rating	Class B - Maximum Load at 10.2 tons

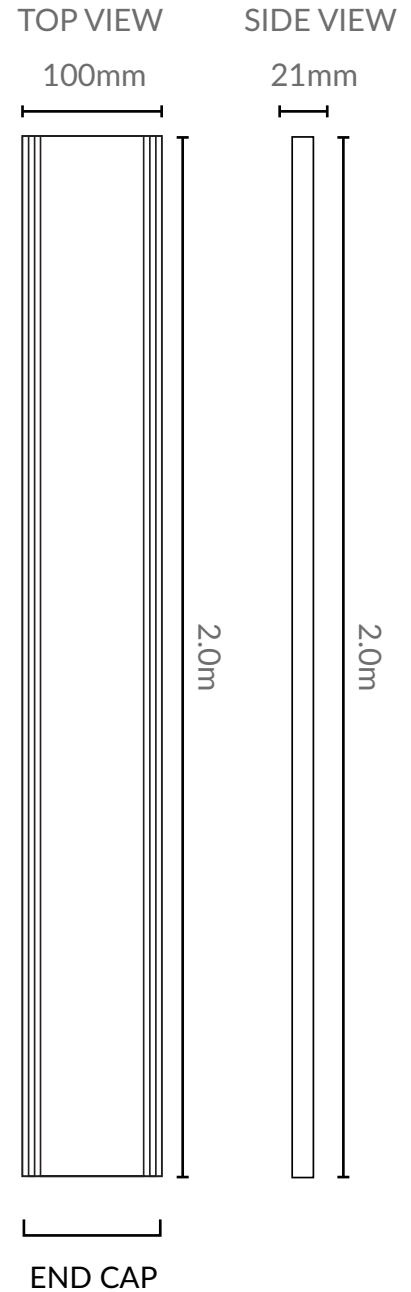

Minimum 72mm waste outlet recommended

* Regular, gentle cleaning with soapy water is recommended. Do not use abrasive cloths or acidic chemicals on the grates.

PRODUCT SPECIFICATIONS

Product	Slimline Tile Insert 21 (STI21)
Code	STI21-S-3, STI21-M-3, STI21-G-3, STI21-BN-3
Colours Available	Silver, Midnight, Gold, Brushed Nickel
Length	3000mm
Width	100mm
Depth	21mm
Material	Anodised Aluminium
Weight	4.3kg
Applications	Indoor and Outdoor
Features	<ul style="list-style-type: none"> • Thinnest Tile Insert available • Suitable for tiles up to 10mm thick • Easy roll out feature for cleaning and maintenance • Lifetime Rustproof Warranty • UV Stable
Scope of Use	DN90 72mm and 80mm
Load Rating	Class B - Maximum Load at 10.2 tons

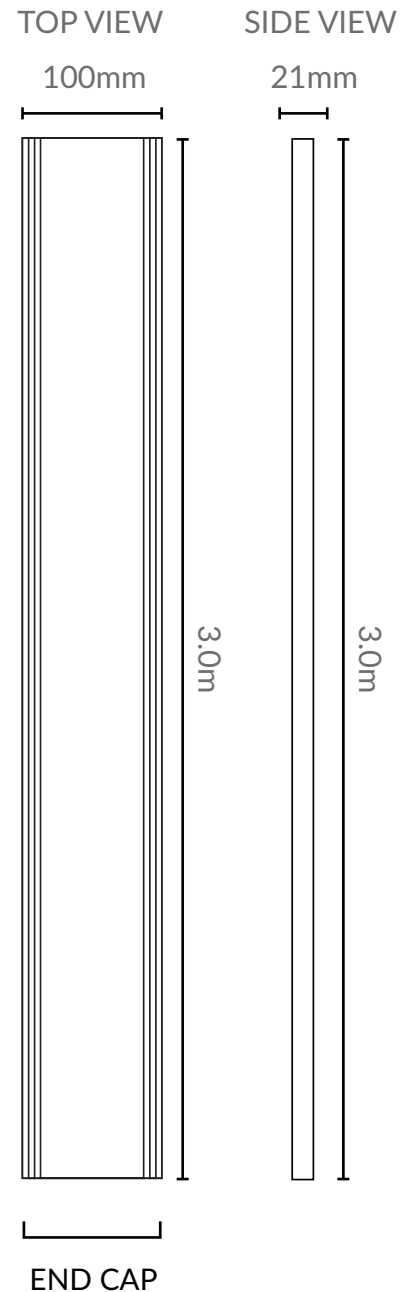

Minimum 72mm waste outlet recommended

* Total length of full grate is 3.2m, total usable length is 3.0m to allow for any wastage during the anodising process.

* Regular, gentle cleaning with soapy water is recommended. Do not use abrasive cloths or acidic chemicals on the grates.

Warranty information and Care & Maintenance can be found at www.lauxesgrates.com.au

PRODUCT SPECIFICATIONS

Product	Slimline Tile Insert 21 (STI21)
Code	STI21-S-5.6, STI21-M-5.6, STI21-G-5.6, STI21-BN-5.6
Colours Available	Silver, Midnight, Gold, Brushed Nickel
Length	5600mm
Width	100mm
Depth	21mm
Material	Anodised Aluminium
Weight	7.8kg
Applications	Indoor and Outdoor
Features	<ul style="list-style-type: none"> • Thinnest Tile Insert available • Suitable for tiles up to 10mm thick • Easy roll out feature for cleaning and maintenance • Lifetime Rustproof Warranty • UV Stable
Scope of Use	DN90 72mm and 80mm
Load Rating	Class B - Maximum Load at 10.2 tons

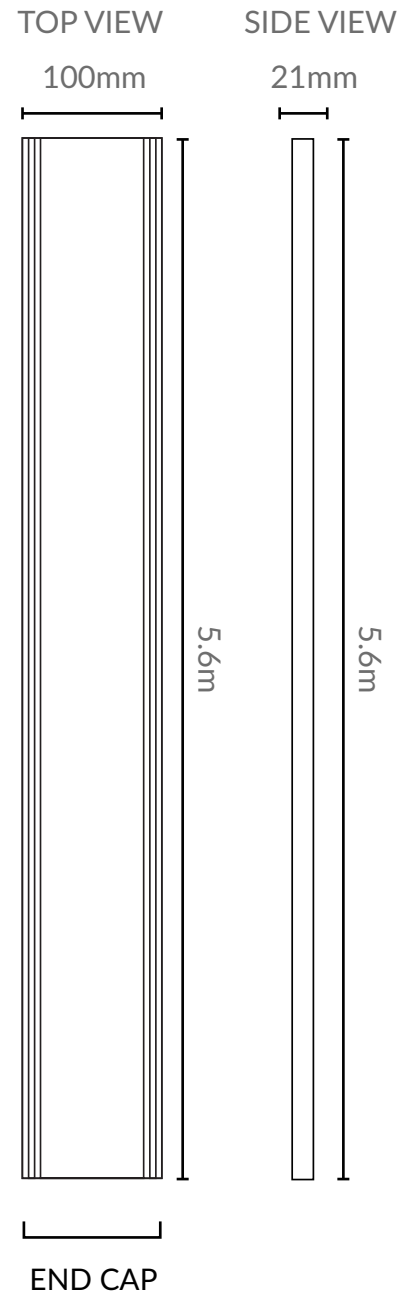

Minimum 72mm waste outlet recommended

* Total length of full grate is 5.8m, total usable length is 5.6m to allow for any wastage during the anodising process.

* Regular, gentle cleaning with soapy water is recommended. Do not use abrasive cloths or acidic chemicals on the grates.

Warranty information and Care & Maintenance can be found at www.lauxesgrates.com.au

PRODUCT SPECIFICATIONS

Product	Slimline Tile Insert 26 (STI26)
Code	STI26-S-1, STI26-M-1, STI26-G-1, STI26-BN-1
Colours Available	Silver, Midnight, Gold, Brushed Nickel
Length	1000mm
Width	100mm
Depth	26mm
Material	Anodised Aluminium
Weight	1.6kg
Applications	Indoor and Outdoor
Features	<ul style="list-style-type: none"> • No visible holes • Suitable for tiles up to 11mm thick • Easy roll out feature for cleaning and maintenance • Anti-water tracking design • Lifetime Rustproof Warranty • UV Stable
Scope of Use	DN 90 40mm, 50mm, 72mm, 80mm
Load Rating	Class B - Maximum Load at 10.2 tons

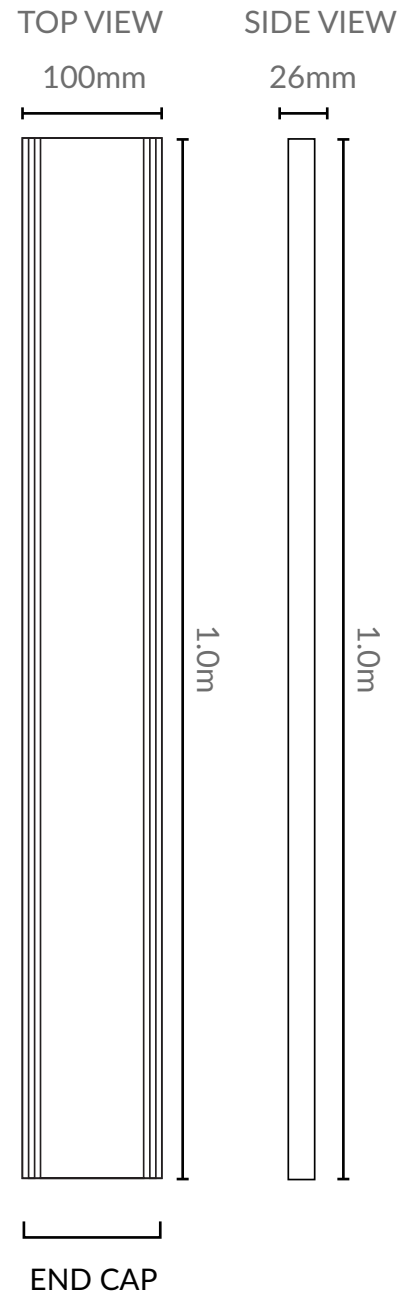

* Regular, gentle cleaning with soapy water is recommended. Do not use abrasive cloths or acidic chemicals on the grates.

PRODUCT SPECIFICATIONS

Product	Slimline Tile Insert 26 (STI26)
Code	STI26-S-1.6, STI26-M-1.6, STI26-G-1.6, STI26-BN-1.6
Colours Available	Silver, Midnight, Gold, Brushed Nickel
Length	1600mm
Width	100mm
Depth	26mm
Material	Anodised Aluminium
Weight	2.5kg
Applications	Indoor and Outdoor
Features	<ul style="list-style-type: none"> • No visible holes • Suitable for tiles up to 11mm thick • Easy roll out feature for cleaning and maintenance • Anti-water tracking design • Lifetime Rustproof Warranty • UV Stable
Scope of Use	DN 90 40mm, 50mm, 72mm, 80mm
Load Rating	Class B - Maximum Load at 10.2 tons

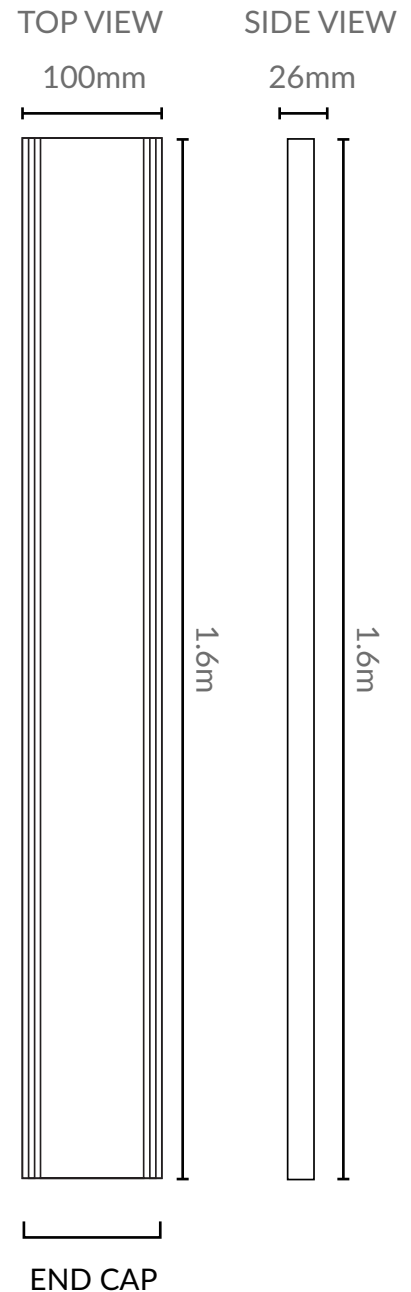

* Regular, gentle cleaning with soapy water is recommended. Do not use abrasive cloths or acidic chemicals on the grates.

PRODUCT SPECIFICATIONS

Product	Slimline Tile Insert 26 (STI26)
Code	STI26-S-2, STI26-M-2, STI26-G-2, STI26-BN-2
Colours Available	Silver, Midnight, Gold, Brushed Nickel
Length	2000mm
Width	100mm
Depth	26mm
Material	Anodised Aluminium
Weight	3.1kg
Applications	Indoor and Outdoor
Features	<ul style="list-style-type: none"> • No visible holes • Suitable for tiles up to 11mm thick • Easy roll out feature for cleaning and maintenance • Anti-water tracking design • Lifetime Rustproof Warranty • UV Stable
Scope of Use	DN 90 40mm, 50mm, 72mm, 80mm
Load Rating	Class B - Maximum Load at 10.2 tons

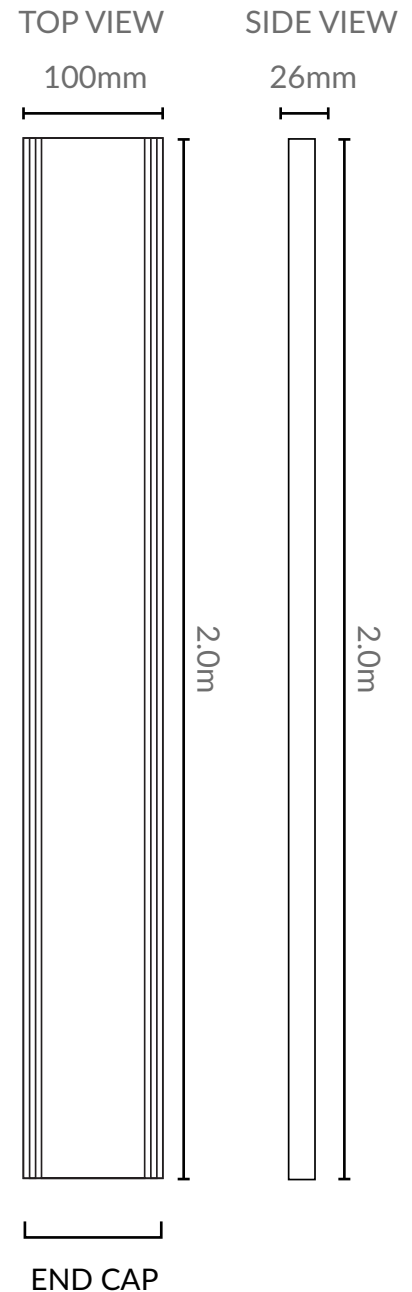

* Regular, gentle cleaning with soapy water is recommended. Do not use abrasive cloths or acidic chemicals on the grates.

PRODUCT SPECIFICATIONS

Product	Slimline Tile Insert 26 (STI26)
Code	STI26-S-3, STI26-M-3, STI26-G-3, STI26-BN-3
Colours Available	Silver, Midnight, Gold, Brushed Nickel
Length	3000mm
Width	100mm
Depth	26mm
Material	Anodised Aluminium
Weight	4.7kg
Applications	Indoor and Outdoor
Features	<ul style="list-style-type: none"> • No visible holes • Suitable for tiles up to 11mm thick • Easy roll out feature for cleaning and maintenance • Anti-water tracking design • Lifetime Rustproof Warranty • UV Stable
Scope of Use	DN 90 40mm, 50mm, 72mm, 80mm
Load Rating	Class B - Maximum Load at 10.2 tons

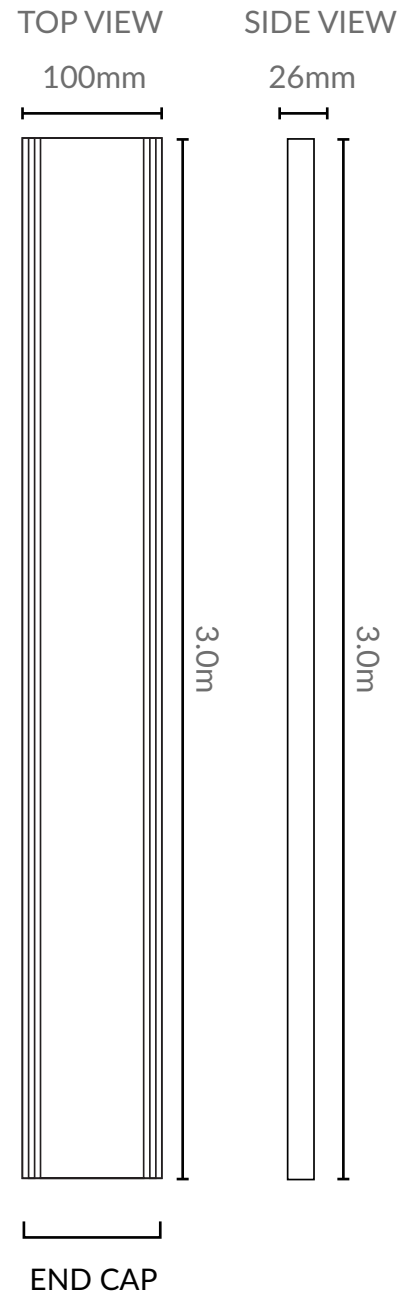

* Total length of full grate is 3.2m, total usable length is 3.0m to allow for any wastage during the anodising process.

* Regular, gentle cleaning with soapy water is recommended. Do not use abrasive cloths or acidic chemicals on the grates.

PRODUCT SPECIFICATIONS

Product	Slimline Tile Insert 26 (STI26)
Code	STI26-S-5.6, STI26-M-5.6, STI26-G-5.6, STI26-BN-5.6
Colours Available	Silver, Midnight, Gold, Brushed Nickel
Length	5600mm
Width	100mm
Depth	26mm
Material	Anodised Aluminium
Weight	9.0kg
Applications	Indoor and Outdoor
Features	<ul style="list-style-type: none"> • No visible holes • Suitable for tiles up to 11mm thick • Easy roll out feature for cleaning and maintenance • Anti-water tracking design • Lifetime Rustproof Warranty • UV Stable
Scope of Use	DN 90 40mm, 50mm, 72mm, 80mm
Load Rating	Class B - Maximum Load at 10.2 tons

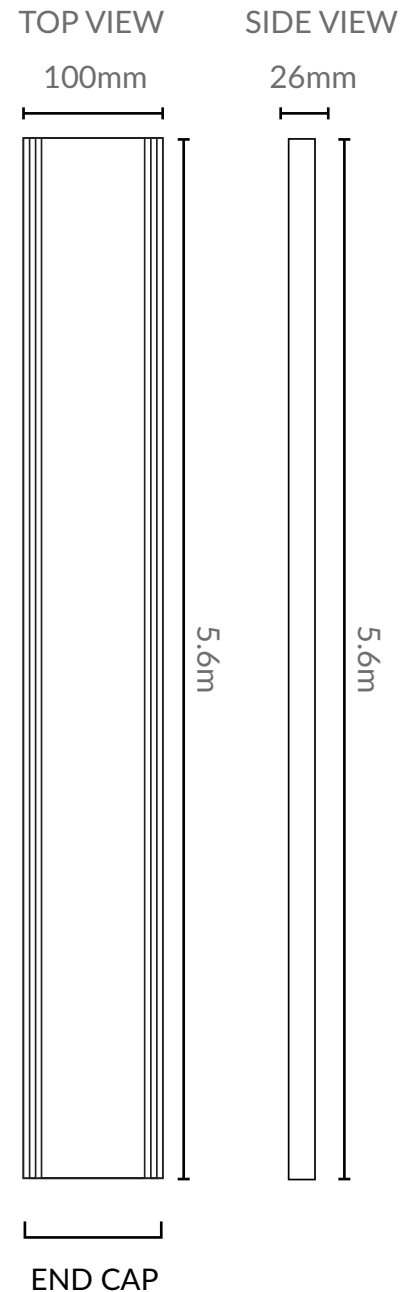

* Total length of full grate is 5.8m, total usable length is 5.6m to allow for any wastage during the anodising process.

* Regular, gentle cleaning with soapy water is recommended. Do not use abrasive cloths or acidic chemicals on the grates.

PRODUCT SPECIFICATIONS

Product	Tile Insert Plus (TIP35)
Code	TIP35-S-1, TIP35-M-1
Colours Available	Silver, Midnight
Length	1000mm
Width	100mm
Depth	35mm
Material	Anodised Aluminium
Weight	1.9kg
Applications	Outdoor
Features	<ul style="list-style-type: none"> • Perfect for large format tiles such as travertine or stone • Recommended for outdoor usage • Suitable for tiles up to 20mm thick • Easy roll out feature for cleaning and maintenance • Lifetime Rustproof Warranty • UV Stable
Scope of Use	DN90 40mm, 50mm, 72mm and 80mm
Load Rating	Class B - Maximum Load at 10.2 tons

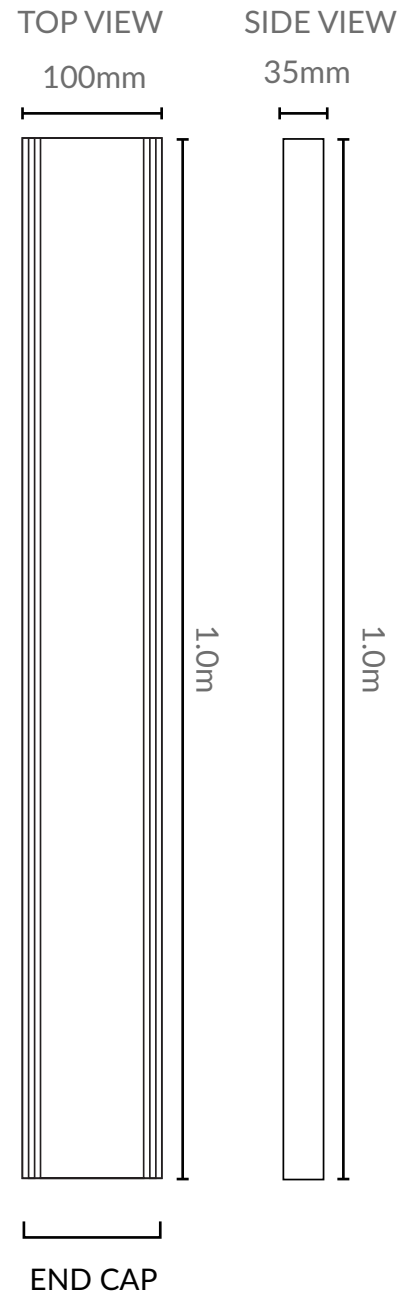

* Regular, gentle cleaning with soapy water is recommended. Do not use abrasive cloths or acidic chemicals on the grates.

Warranty information and Care & Maintenance can be found at www.lauxesgrates.com.au

PRODUCT SPECIFICATIONS

Product	Tile Insert Plus (TIP35)
Code	TIP35-S-1.6, TIP35-M-1.6
Colours Available	Silver, Midnight
Length	1600mm
Width	100mm
Depth	35mm
Material	Anodised Aluminium
Weight	3.0kg
Applications	Outdoor
Features	<ul style="list-style-type: none"> • Perfect for large format tiles such as travertine or stone • Recommended for outdoor usage • Suitable for tiles up to 20mm thick • Easy roll out feature for cleaning and maintenance • Lifetime Rustproof Warranty • UV Stable
Scope of Use	DN90 40mm, 50mm, 72mm and 80mm
Load Rating	Class B - Maximum Load at 10.2 tons

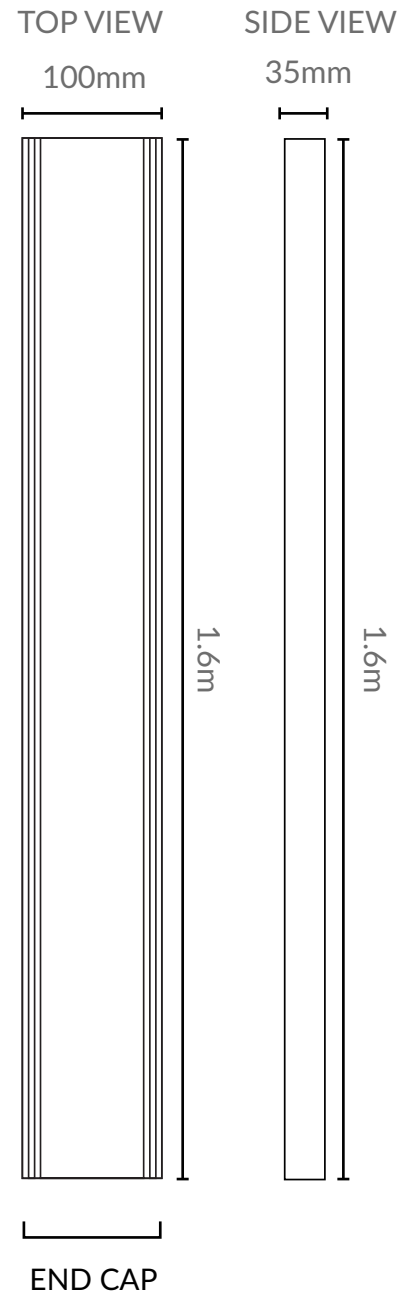

* Regular, gentle cleaning with soapy water is recommended. Do not use abrasive cloths or acidic chemicals on the grates.

Warranty information and Care & Maintenance can be found at www.lauxesgrates.com.au

PRODUCT SPECIFICATIONS

Product	Tile Insert Plus (TIP35)
Code	TIP35-S-2, TIP35-M-2
Colours Available	Silver, Midnight
Length	2000mm
Width	100mm
Depth	35mm
Material	Anodised Aluminium
Weight	3.8kg
Applications	Outdoor
Features	<ul style="list-style-type: none"> • Perfect for large format tiles such as travertine or stone • Recommended for outdoor usage • Suitable for tiles up to 20mm thick • Easy roll out feature for cleaning and maintenance • Lifetime Rustproof Warranty • UV Stable
Scope of Use	DN90 40mm, 50mm, 72mm and 80mm
Load Rating	Class B - Maximum Load at 10.2 tons

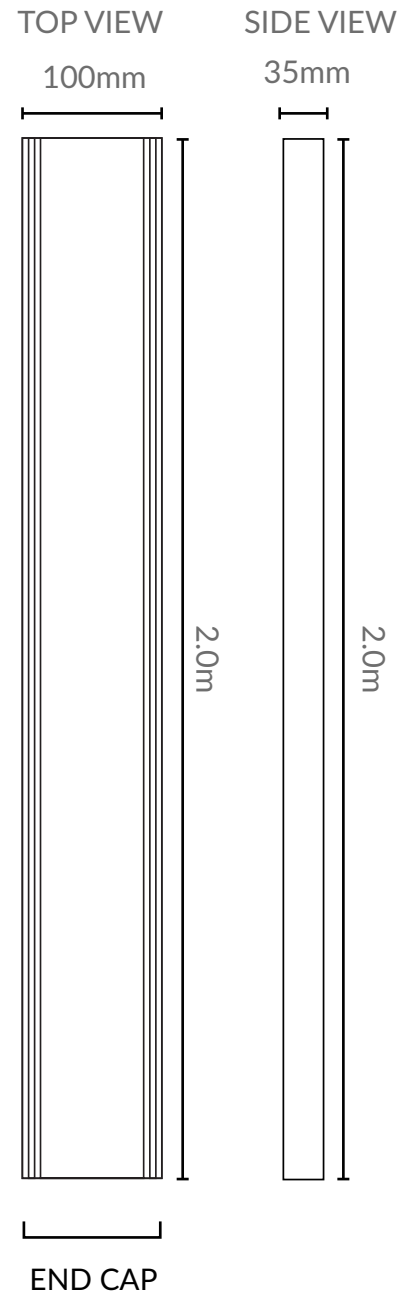

* Regular, gentle cleaning with soapy water is recommended. Do not use abrasive cloths or acidic chemicals on the grates.

Warranty information and Care & Maintenance can be found at www.lauxesgrates.com.au

PRODUCT SPECIFICATIONS

Product	Tile Insert Plus (TIP35)
Code	TIP35-S-3, TIP35-M-3
Colours Available	Silver, Midnight
Length	3000mm
Width	100mm
Depth	35mm
Material	Anodised Aluminium
Weight	5.7kg
Applications	Outdoor
Features	<ul style="list-style-type: none"> • Perfect for large format tiles such as travertine or stone • Recommended for outdoor usage • Suitable for tiles up to 20mm thick • Easy roll out feature for cleaning and maintenance • Lifetime Rustproof Warranty • UV Stable
Scope of Use	DN90 40mm, 50mm, 72mm and 80mm
Load Rating	Class B - Maximum Load at 10.2 tons

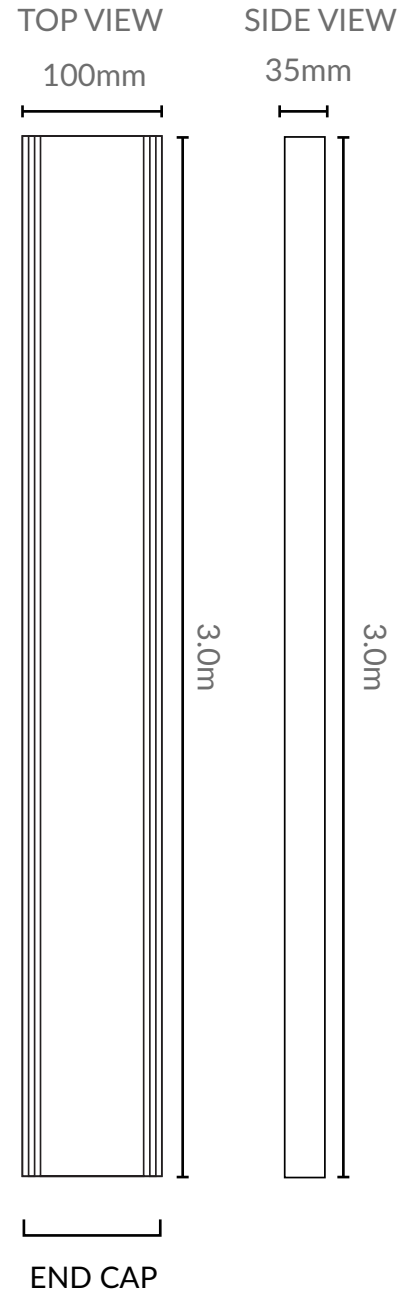

* Total length of full grate is 3.2m, total usable length is 3.0m to allow for any wastage during the anodising process.

* Regular, gentle cleaning with soapy water is recommended. Do not use abrasive cloths or acidic chemicals on the grates.

Warranty information and Care & Maintenance can be found at www.lauxesgrates.com.au

PRODUCT SPECIFICATIONS

Product	Tile Insert Plus (TIP35)
Code	TIP35-S-5.6, TIP35-M-5.6
Colours Available	Silver, Midnight
Length	5600mm
Width	100mm
Depth	35mm
Material	Anodised Aluminium
Weight	11.0kg
Applications	Outdoor
Features	<ul style="list-style-type: none"> • Perfect for large format tiles such as travertine or stone • Recommended for outdoor usage • Suitable for tiles up to 20mm thick • Easy roll out feature for cleaning and maintenance • Lifetime Rustproof Warranty • UV Stable
Scope of Use	DN90 40mm, 50mm, 72mm and 80mm
Load Rating	Class B - Maximum Load at 10.2 tons

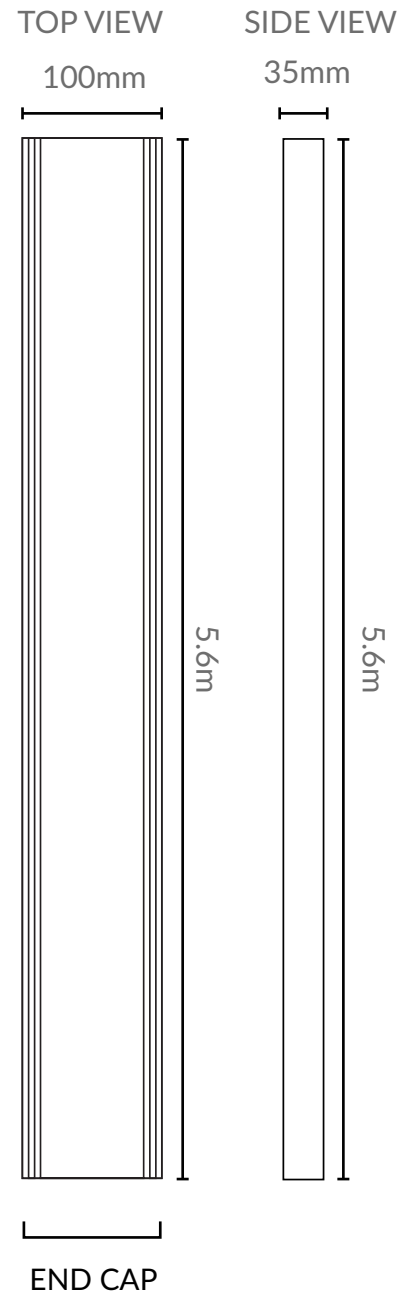

* Total length of full grate is 5.8m, total usable length is 5.6m to allow for any wastage during the anodising process.

* Regular, gentle cleaning with soapy water is recommended. Do not use abrasive cloths or acidic chemicals on the grates.

Warranty information and Care & Maintenance can be found at www.lauxesgrates.com.au